

DWG REF	QTY	PART NUMBER	DESCRIPTION	MATERIAL
SHELL				
1*	1	99301	SHELL	Filament Wound Epoxy/Glass composite - Head locking grooves integrally wound in place.
HEAD				
2	2	194746	Bearing Plate Assembly	-
2.1*	1	51050	Bearing Plate	SB-221 A96061-T6
2.2	1	45070	Danger Label	-
3	2	96003	Sealing Plate	Engineering Thermoplastic.
4*	2	50607	Feed/Conc Port	SA-312 316L
5	2	45247	Port Retainer	Stainless Steel.
6	2	97980	Permeate Port	Engineering Thermoplastic.
7	2	45066	Port Nut	Engineering Thermoplastic.
8	2	196223	Head Seal	Ethylene Propylene - O Ring.
9	4	196215	Port Seal	Ethylene Propylene - O Ring.
HEAD INTERLOCK				
10*	2	47336	Quick Release Retaining Ring	SA-479 316
VESSEL SUPPORT				
11	2*	52169	Saddle	Engineering Thermoplastic.
12	2*	45042	Strap Assy.	304 Stainless Steel-PVC Cushion.
13	4**	46265	Strap screw.	5/16-18 UNC, 2.5"-L, 304 Stainless Steel.
ELEMENT INTERFACE				
14	2	A/R	Adapter	Engineering Thermoplastic.
15	4	A/R	PWT Seal	Ethylene Propylene - O - Ring
16	2	196222	Adapter seal	Ethylene Propylene - O - Ring
17	1	45069	Thrust Ring	Engineering Thermoplastic.

*3 & **6 each furnished with length code 4,5,6,7 & 8.

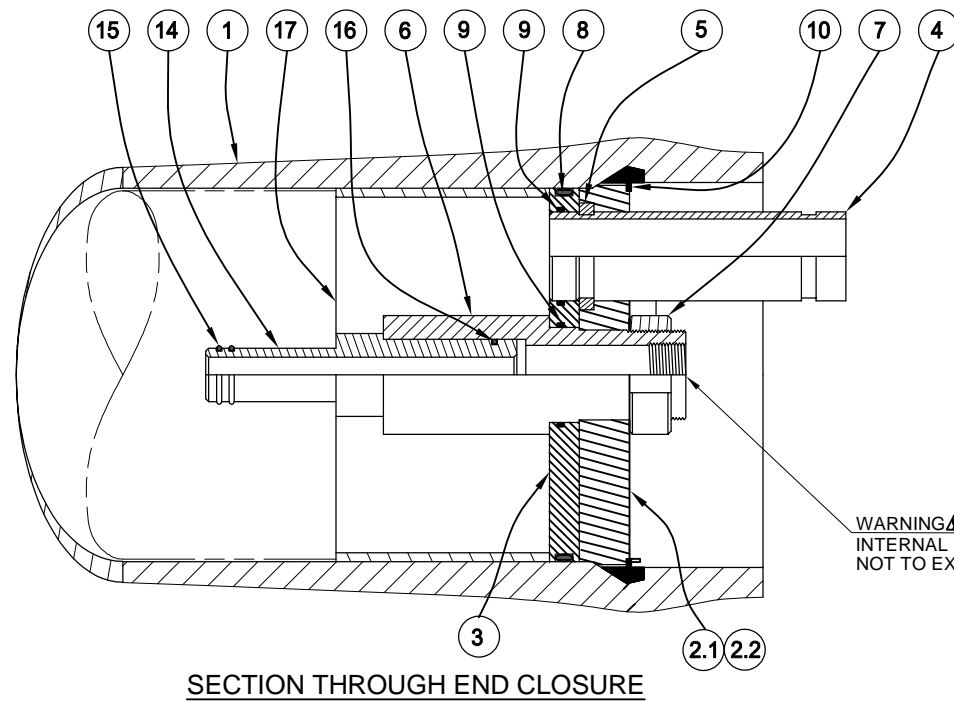

Dash Length	L IN(MM)	F IN(MM)	S IN(MM)	Approx Weight LB(KG)**
-1	61 (1549)	57.63 (1464)	30X1 (762)	41 (18)
-2	101 (2565)	97.63 (2480)	70X1 (1778)	51 (23)
-3	141 (3581)	137.63 (3496)	110X1 (2794)	62 (28)
-4	181 (4597)	177.63 (4512)	75X2 (1905)	72 (33)
-5	221 (5613)	217.63 (5528)	95X2 (2413)	83 (38)
-6	261 (6629)	257.63 (6544)	115X2 (2921)	93 (42)
-7	301 (7645)	297.63 (7560)	135X2 (3429)	104 (47)
-8	341 (8661)	337.63 (8576)	155X2 (3937)	114 (52)

GENERAL NOTES:

- DIMENSIONS ARE IN INCHES (MM APPROX.).
- SHELL EXTERIOR COATED WITH WHITE RAL 9003, HIGH GLOSS POLYURETHANE PAINT.
- ITEM 17 DOWNSTREAM ONLY.
- NOT TO BE USED FOR CONSTRUCTION UNLESS CERTIFIED BY PENTAIR.
- GENERAL TOLERANCES APPLY, FOR DETAILS CONTACT FACTORY.
- "L" REFERS TO OVERALL LENGTH OF THE VESSEL.
- ASME PARTS.
- APPROX. WEIGHT REFERS TO SHELL WEIGHT INCLUDING HEAD ASSEMBLIES WITHOUT MEMBRANES.

THIS DOCUMENT AND THE INFORMATION CONTAINED HEREIN, ARE THE CONFIDENTIAL AND PROPRIETARY INFORMATION OF PENTAIR WATER INDIA PVT. LTD. PENTAIR WATER INDIA PVT. LTD. IS THE SOLE OWNER OF THE INFORMATION AND PROCESSES DEFINED HEREIN. THIS DOCUMENT, AND THE INFORMATION CONTAINED, MAY NOT BE DISCLOSED, REPRODUCED, DUPLICATED, USED, SOLD, PUBLISHED, COMMUNICATED OR OTHERWISE DISTRIBUTED, IN WHOLE OR IN PART, FOR ANY PURPOSE WITHOUT THE EXPRESS WRITTEN CONSENT OF PENTAIR WATER INDIA PVT. LTD. THIS DOCUMENT AND ANY COPIES, IN ALL APPLICABLE FORMATS, SHALL BE RETURNED TO PENTAIR WATER INDIA PVT. LTD. UPON REQUEST.

ALL INDICATED PENTAIR TRADEMARKS AND LOGOS ARE PROPERTY OF PENTAIR. THIRD PARTY REGISTERED AND UNREGISTERED TRADEMARKS AND LOGOS ARE PROPERTY OF THEIR RESPECTIVE OWNERS. BECAUSE WE ARE CONTINUOUSLY IMPROVING OUR PRODUCTS AND SERVICES, PENTAIR RESERVES THE RIGHT TO CHANGE SPECIFICATIONS WITHOUT PRIOR NOTICE. PENTAIR IS AN EQUAL OPPORTUNITY EMPLOYER.

©2021 Pentair. All Rights Reserved.



DRAWN BY: KK	DRAWING DESCRIPTION: MODEL - 80E30 MEMBRANE HOUSING	DRAWING NO.: 99111	REV.: Z
DATE: 10APR15	CUSTOMER NAME:	VESSEL MODEL: 80E30	
CHECKED BY: KPS	PROJECT NAME:	TOTAL QTY:	
DATE: 10APR15	CUSTOMER P.O.#:	SIZE: A3	SCALE: NONE
APPROVED BY: MKS	REV. DATE: 16JAN23	PAGE NO.: 01 OF 02	

RATING:

DESIGN PRESSURE.....300 PSI
(2.07 MPa)
MAX. OPERATING TEMP.....120°F
(49°C)
MIN. OPERATING TEMP.....20°F
(-7°C)
FACTORY TEST PRESSURE.....CE/ASME
450 / 330 PSI
(3.10MPa) / (2.28 MPa)
BURST PRESSURE.....1800 PSI
(12.41 MPa)

INTENDED USE:

The CodeLine Model 80E30 Fiberglass RO Pressure Vessel is designed for continuous, long term use as housing for reverse osmosis membrane elements to desalt typical brackish waters at pressures up to 300 psi. Any make of eight-inch nominal diameter spiral-wound element is easily accommodated; the appropriate interfacing hardware for the element specified is furnished with the vessel.

The CodeLine Model 80E30 is designed in accordance with the engineering standards of the Boiler and Pressure Vessel Code of the American Society of Mechanical Engineers (ASME Code) Section X Edition 2021. F/C port, Bearing plate and Quick release spiral ring are designed as per ASME Section VIII Division I Edition 2021.

At small additional cost, vessels can be inspected during construction by an ASME Authorized inspector and ASME Code stamped.

The CodeLine Model 80E30 must be installed, operated and maintained in accordance with the listed precautions and good industrial practice to assure safe operation over a long service life.

The high performance reinforced plastic shell must be allowed to expand under pressure; undue restraint at support points or piping connections can cause leaks to develop in the shell. The end closure, incorporating close fitting, interlocking metal components, must be kept dry and free of corrosion; deterioration can lead to catastrophic mechanical failure of the head.

The end closures, incorporating close-fitting, interlocking metal components, must be kept dry and free of corrosion; deterioration can lead to catastrophic mechanical failure of the heads.

Pentair will assist the purchaser in determining the suitability of this standard vessel for their specific operating conditions. The final determination however, including evaluation of the standard material of construction for compatibility with the specific corrosive environment, shall be the responsibility of the purchaser.

Specifications are subject to change without notice.

PRECAUTIONS:

- DO...read, understand and follow all instructions; failure to take every precaution will void warranty and may result in vessel failure
- DO...mount the shell on horizontal members at span "S" using complaint vessel supports furnished; tighten hold down straps just snug
- DO...provide overpressure protection for vessel set at not more than 105% of design pressure
- DO...inspect end closures regularly; replace components that have deteriorated and correct causes of corrosion
- DO NOT... make rigid piping connections to ports or clamp vessel in any way that resists growth of fiberglass shell under pressure; ΔDIA = 0.015 in. (0.4mm) and ΔL = 0.2 in. (5mm) for a length code -8 vessel
- DO NOT... hang piping manifolds from ports or use vessel in any way to support other components; branch connection piping may be simply supported between the header and port; maximum weight of branch piping; feed/concentrate – 16 lbs (7.3 kg); Permeate – 8 lbs (3.6 kg)
- DO NOT... operate vessel at pressures and temperatures in excess of its rating
- DO NOT... operate vessel without permeate ports internally connected with a complete set of elements and interconnecting hardware
- DO NOT... operate vessel with permeate pressure in excess of 125 psi at 120°F (0.86 MPa at 49°C)
- DO NOT... overtighten the connection to the permeate port (hand-tighten plus one-quarter turn, check for leaks)
- DO NOT... tolerate leaks or allow end closures to be routinely wetted in any way
- DO NOT... pressurize vessel until double-checking to verify that the retaining ring is completely inside the groove
- DO NOT... work on any component until first verifying that pressure is relieved from vessel
- DO NOT... operate outside the pH range 3-11.

ORDERING:

Using the chart below, please check the features you require and fax them with your purchase order to our customer service department for expedited processing.
For optional materials and/or features not listed below, please consult factory for pricing and availability.

Please note that we require your membrane brand and model number when ordering. If this information is not initially available, you may provide it at a later date by checking the appropriate box below.

VESSEL LENGTH CODE – please check one

MODEL 80E30 -1 -2 -3 -4 -5 -6 -7 -8

MEMBRANE BRAND AND MODEL – please check one and fill in information

Please supply adapters for the following membrane brand and specific model
Brand _____ Model _____

CERTIFICATION REQUIRED

- Hydro testing at 1.5 times the design pressure.
 - CE Marked
- Hydro testing at 1.1 times the design pressure.
 - ASME Stamped and National Board Registered.
 - In compliance with the ASME Sec X but not Code Stamped.

EXTERIOR FINISH – please check one

- White high-gloss RAL 9003 polyurethane coating.
- Optional colors are available for 50 or more vessels per order. Call factory for pricing details.

MATERIAL OPTIONS

- All materials as per drawing on the first page.
- Customer specified materials: -
(Please consult the factory, as these options will affect pricing and vessel lead-time.)

For complete information on proper use of this vessel please refer to the 80E series USER'S GUIDE Bulletin 523004.

THIS DOCUMENT AND THE INFORMATION CONTAINED HEREIN, ARE THE CONFIDENTIAL AND PROPRIETARY INFORMATION OF PENTAIR WATER INDIA PVT. LTD. PENTAIR WATER INDIA PVT. LTD. IS THE SOLE OWNER OF THE INFORMATION AND PROCESSES DEFINED HEREIN. THIS DOCUMENT, AND THE INFORMATION CONTAINED, MAY NOT BE DISCLOSED, REPRODUCED, DUPLICATED, USED, SOLD, PUBLISHED, COMMUNICATED OR OTHERWISE DISTRIBUTED, IN WHOLE OR IN PART, FOR ANY PURPOSE WITHOUT THE EXPRESS WRITTEN CONSENT OF PENTAIR WATER INDIA PVT. LTD. THIS DOCUMENT AND ANY COPIES, IN ALL APPLICABLE FORMATS, SHALL BE RETURNED TO PENTAIR WATER INDIA PVT. LTD. UPON REQUEST.

ALL INDICATED PENTAIR TRADEMARKS AND LOGOS ARE PROPERTY OF PENTAIR. THIRD PARTY REGISTERED AND UNREGISTERED TRADEMARKS AND LOGOS ARE PROPERTY OF THEIR RESPECTIVE OWNERS. BECAUSE WE ARE CONTINUOUSLY IMPROVING OUR PRODUCTS AND SERVICES, PENTAIR RESERVES THE RIGHT TO CHANGE SPECIFICATIONS WITHOUT PRIOR NOTICE. PENTAIR IS AN EQUAL OPPORTUNITY EMPLOYER.

© 2021 Pentair. All Rights Reserved.



DRAWN BY:	KK	DRAWING DESCRIPTION:	DRAWING NO.:	REV.:
DATE:	10APR15	MODEL - 80E30 MEMBRANE HOUSING	99111	Z
CHECKED BY:	KPS	CUSTOMER NAME:	VESSEL MODEL:	
DATE:	10APR15	-	80E30	
APPROVED BY:	MKS	PROJECT NAME:	TOTAL QTY:	
DATE:	10APR15	-	-	
ECN NO.:	6333	CUSTOMER P.O.#:	SIZE:	SCALE:
REV. DATE:	16JAN23	-	A3	NONE
				PAGE NO.:
				02 OF 02